

WEIGHT(K.G) :-

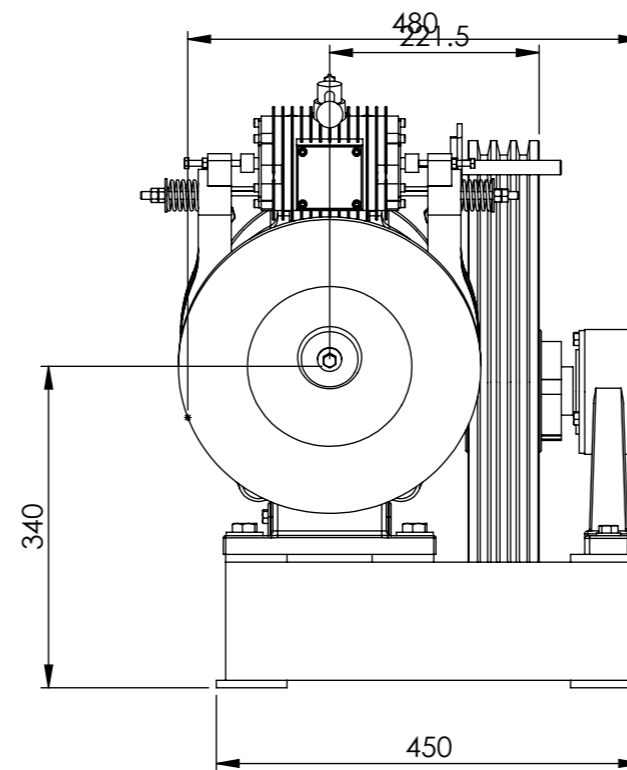
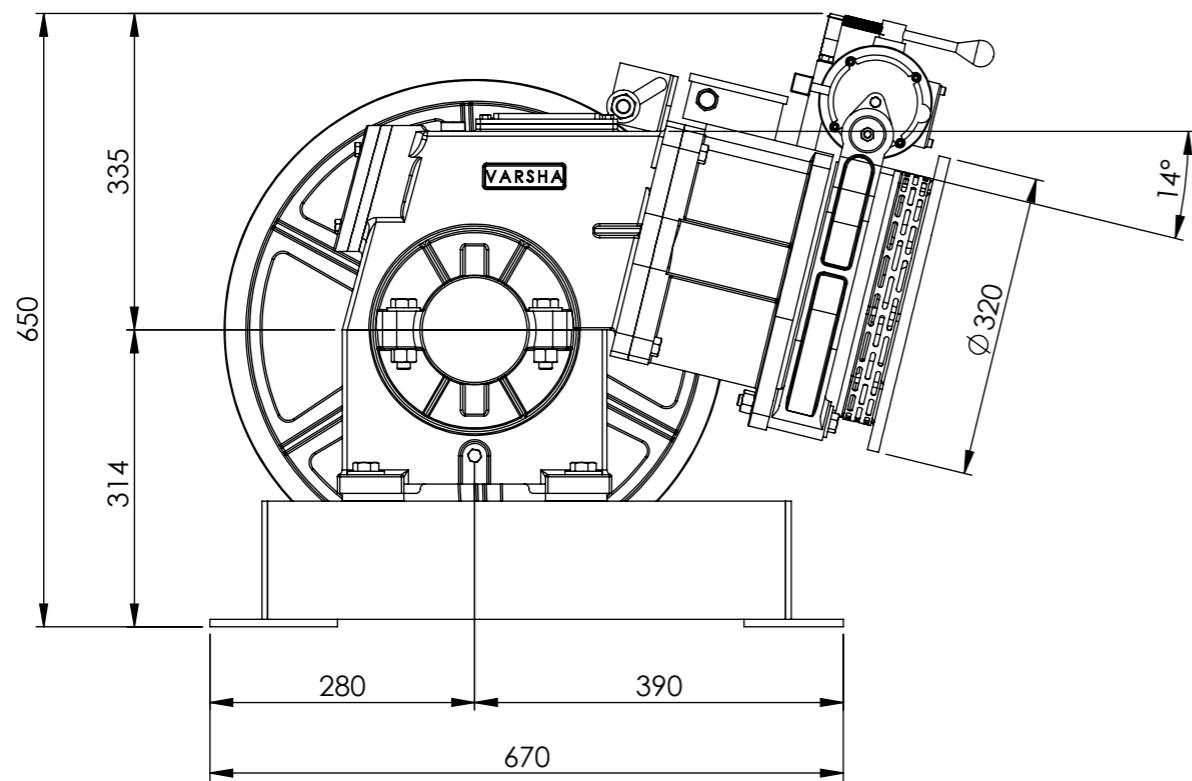
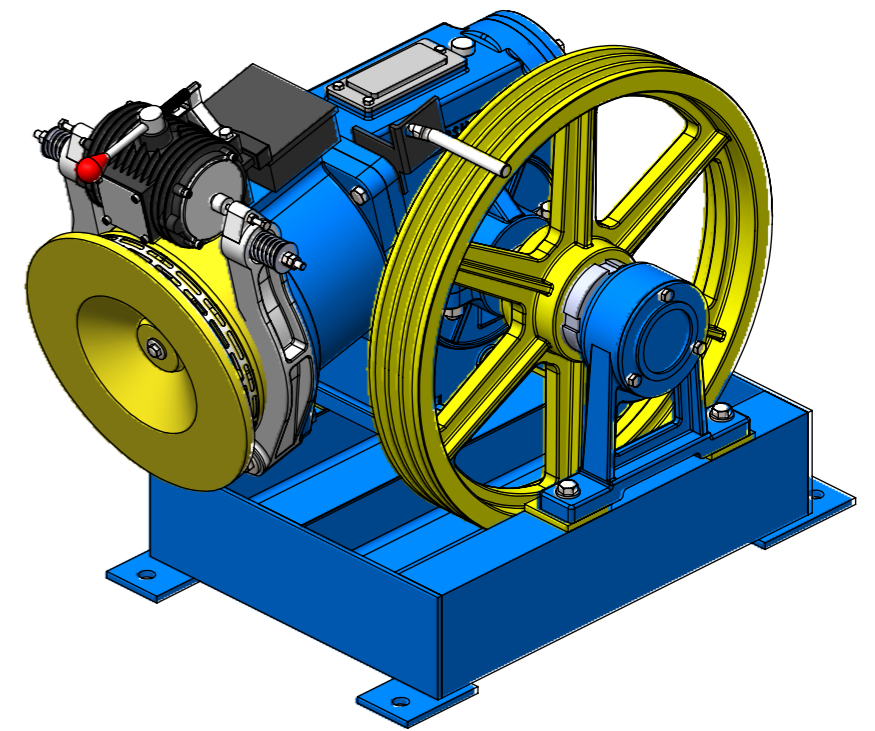
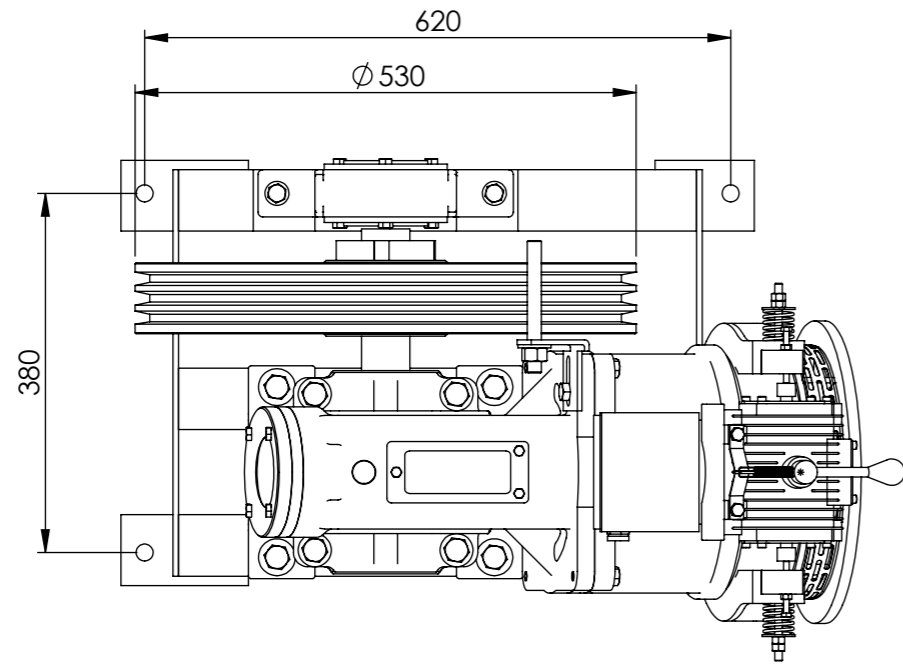

TITLE:—		DRAWN	SCALE	1:1/A3		
VI-61		DATE	MATERIAL			
		CHECKED	QTY.:—			
THIS PRINT IS THE EXCLUSIVE PROPERTY OF SETPL AND IS CONFIDENTIAL IT IS NOT TRANSFERABLE & IS FURNISHED WITH THE CLEAR UNDERSTANDING THAT IT IS NOT BE COPIED WITHOUT PERMISSION AND IS RETURNABLE UPON DEMAND .		HEAT TREAT.:—				
		USED ON:—		GEN. TOL. FOR OPEN DIMN. TO IS:2102 TABLE FOR MEDIUM		
		UNLESS OTHERWISE SPECIFIED BREAK ALL SHARP CORNERS				
ROUGHNESS VALUES	N1=0.025	N4=0.2	N7=1.6	N10=12.5	N12=50	
Ra - MICROMETRE	N2=0.05	N5=0.4	N8=3.2	N11=25		
1micrometre=0.01mm	N3=0.1	N6=0.8	N9=6.3			
VARSHA INDUSTRIES		DRG. NO.:—		REV. SHEET		
info@varshaindustries.com +91-7623044424				1 OF 1		