

WEIGHT(K.G) :-

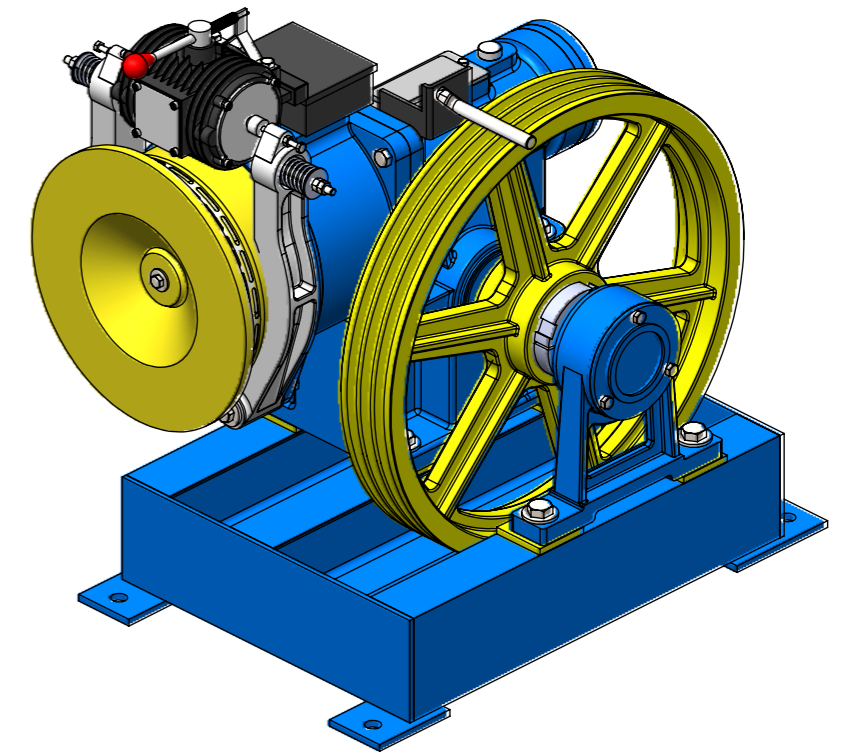
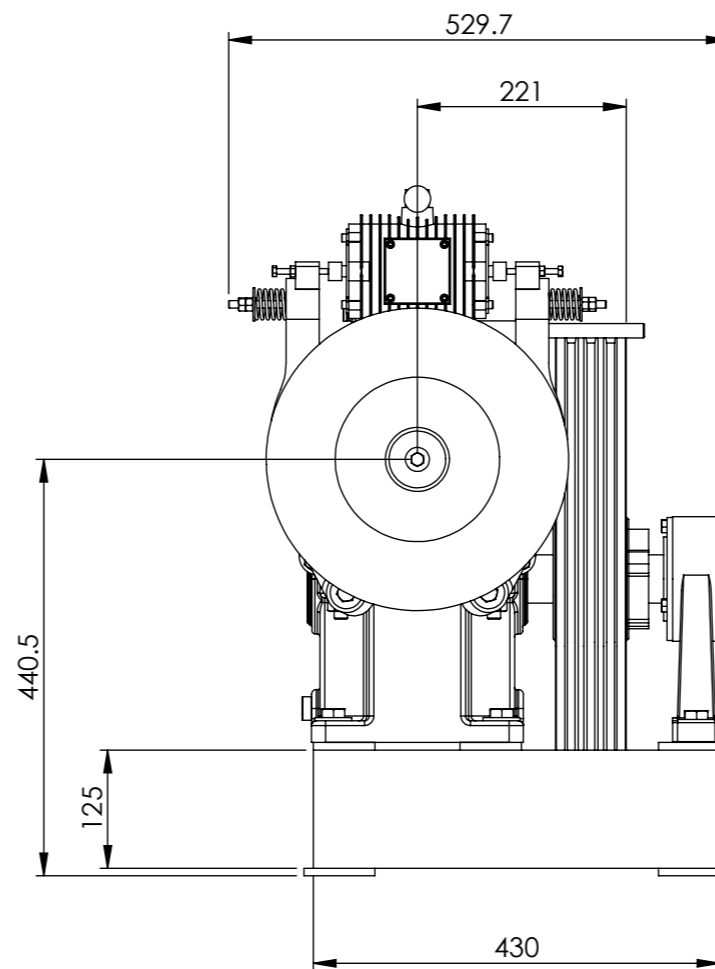
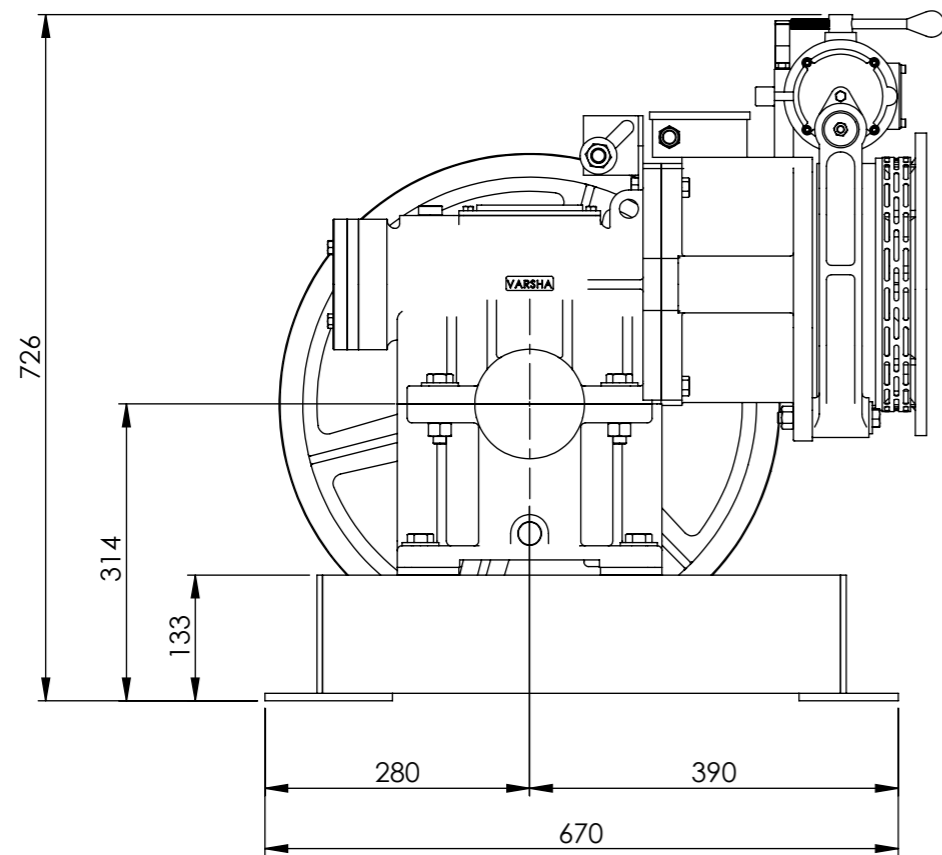
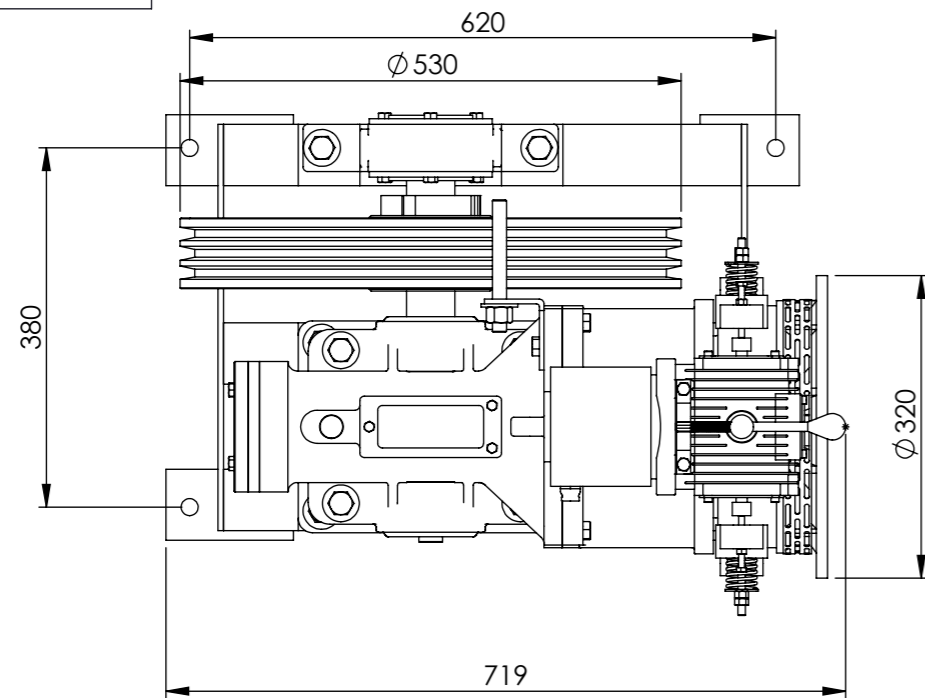

TITLE: - VI-5 UT		DRAWN	SCALE	1:1/A3
		DATE	MATERIAL	
		CHECKED	QTY.:-	
THIS PRINT IS THE EXCLUSIVE PROPERTY OF SETPL AND IS CONFIDENTIAL IT IS NOT TRANSFERABLE & IS FURNISHED WITH THE CLEAR UNDERSTANDING THAT IT IS NOT BE COPIED WITHOUT PERMISSION AND IS RETURNABLE UPON DEMAND .		HEAT TREAT.:-		
		USED ON:-		GEN. TOL. FOR OPEN
		UNLESS OTHERWISE SPECIFIED		DIMN. TO IS:2102
		BREAK ALL SHARP CORNERS		TABLE FOR MEDIUM
ROUGHNESS VALUES	N1=0.025	N4=0.2	N7=1.6	N10=12.5
Ra - MICROMETRE	N2=0.05	N5=0.4	N8=3.2	N11=25
1micrometre=0.01mm	N3=0.1	N6=0.8	N9=6.3	N12=50
VARSHA INDUSTRIES		DRG. NO.:-		REV. SHEET
info@varshaindustries.com +91-7623044424				1 OF 1